

Design and Application Details

The instructions given here are not meant to supercede local code requirements. Check with your local building official for their preference in your area.

Preparation - Be sure that the walls are smooth, without protuberances. Nail ends or points should be removed or pounded flush.

Underlayment - The CSSB recommends No. 30 felt (ASTM D226 Type II or ASTM D4869 Type IV) underlayment material. Apply it horizontally, with a staple gun, starting at the base of the wall, with a 51mm horizontal overlap with each succeeding course, and a 152mm overlap vertically when starting a new roll. Wrap the No. 30 felt underlayment 102mm each way around both inside and outside corners.

Corner Boards - Install corner boards (Figure 8) at this time.

Flashing - Flashings associated with doors, windows, and penetration details should be in accordance with good building practice.

Laying Out - Determine the number of Certi-label courses by measuring the height of the wall at the lowest part of the foundation, from a point 25mm below the top of the foundation, to the top of the wall. Divide the height into equal parts, corresponding closely to the weather exposure, but not exceeding the maximum weather exposure recommended. Transfer this measurement and the number of Certi-label courses to a storypole (Figure 1), to lay out courses on all other walls. Whenever possible butt lines should align with tops or bottoms of windows or other openings, and for appearance the exposure of the final course at the top should match those below.

Certi-label Western Cedar shingle and shake size, exposure, width of joints, width of product, kiln versus air-drying process, moisture content and the local environment will all affect the expansion/contraction of Certi-label Western Cedar sidewall products. These factors should always be taken into consideration when determining the installation details and adequate spacing needed for your specific project. Consult with your installer and refer to Figure 2: Spacing Detail.

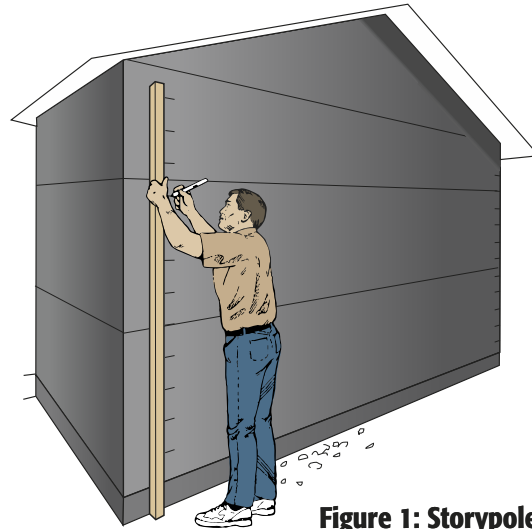

Figure 1: Storypole

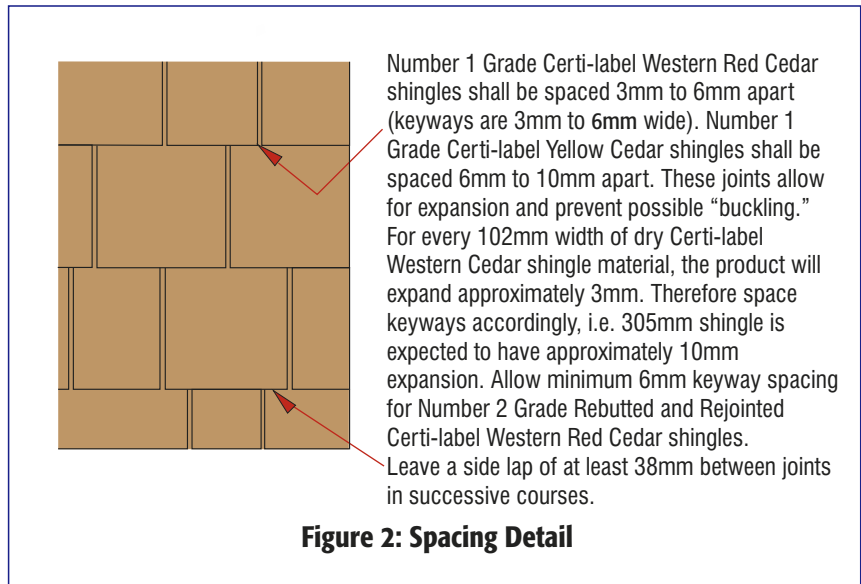

Figure 2: Spacing Detail

Figures 3a and 3b: To prevent the wicking of water, which may cause staining, keep a 13mm clearance between the first course of Certi-label products from all surfaces below.

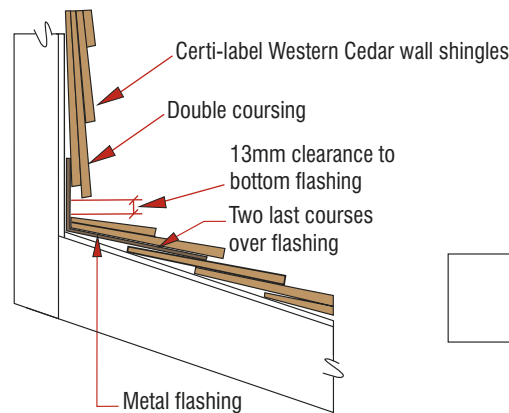

Figure 3a: Flashing

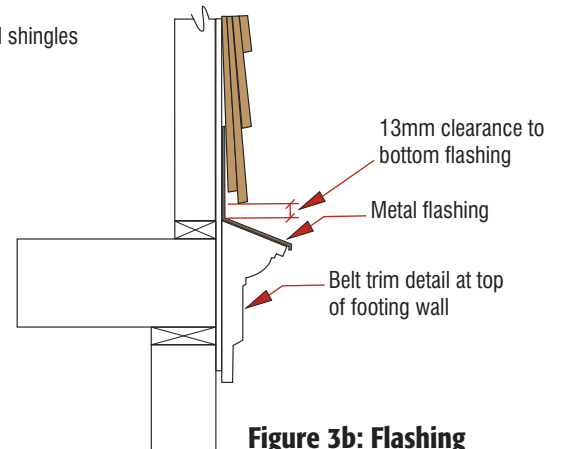

Figure 3b: Flashing